

STEELFLEX™ ROUNDSLINGS

THE STEEL SLING
WITH THE FABRIC FEEL

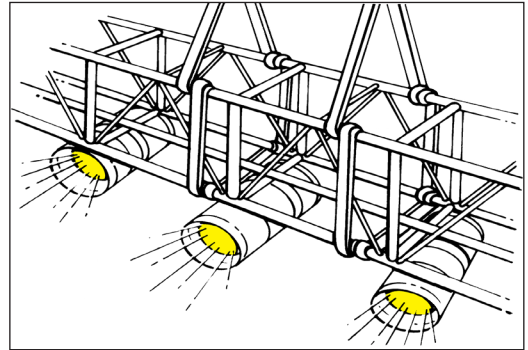

Designed for suspension applications

With safety being of the utmost importance in overhead suspension, *Lift-All's SteelFlex* roundslings combine flexibility, strength and heat resistance (400°F) with the soft feel of fabric to meet your most demanding suspension requirements.

SteelFlex roundslings feature steel galvanized aircraft cable wound in an endless configuration. This wire core is encased in a black double-wall, polyester jacket. A unique inspection window allows for easy inspection of the core for broken wires and corrosion. The result is a highly flexible, easy to use sling that complies with all of the current rigging codes. Stretch at rated capacity is approximately 1%.

Features and Benefits

- Black cover for stage rigging applications.
- No backup rigging required.
- Engineered window allows for core inspection.
- Superior flexibility makes rigging easy.
- Conforms to the load to grip securely.
- Superior cut resistance.

How To Measure



Part Numbers	Weight per Foot (lbs.)	Rated Capacity (lbs.)			Minimum Hardware Dia. (in.)
		Vertical	Choker	Basket	
GACEN40CX18IN	0.60	3,600	3,000	7,200	.625
GACEN40CX2					
GACEN60CX18IN	0.75	5,300	4,200	10,600	.625
GACEN60CX2					
GACEN60X3					
GACEN60X4					
GACEN60X5					
GACEN60X6					
GACEN60X7					
GACEN60X8					
GACEN60X9					
GACEN60X10					
GACEN60X11					
GACEN60X12					

400°F Temperature Rating
NO Wire Rope Backup Needed
Core Inspection Window Standard



1. Maximum length for *SteelFlex* is 12-ft.
2. Sling lengths under 3' use a modified construction and do not have a seamless cover.

- General Information
- Web Slings
- Round Slings
- Sling Protection
- Wire Rope
- Chain Slings
- Rigging Hardware
- Mesh Slings
- Load Huggers
- Tow Products
- Lift-All Hoists
- Hoist Rings
- Plate Clamps
- Lifting Devices